

**• General Description**

The ZMS070N10HP combines advanced trench MOSFET technology with a low resistance package to provide extremely low  $R_{DS(ON)}$ .

**• Features**

- Advance device constructure
- Low  $R_{DS(ON)}$  to minimize conduction loss
- Low Gate Charge for fast switching
- Low Thermal resistance

**• Application**

- Synchronous Rectification for AC-DC/DC-DC converter
- Power Tools

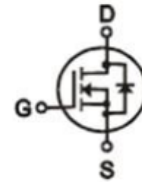
**• Product Summary**

$V_{DS} = 100V$

$R_{DS(ON)} = 7m\Omega$

$I_D = 100A$

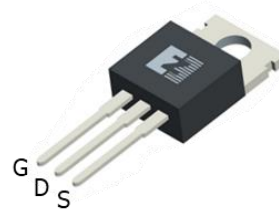
**TO-220**
**• Ordering Information:**

Part NO.	ZMS070N10HP
Marking	ZMS070N10H
Packing Information	Bulk Tube
Basic ordering unit (pcs)	1000

**• Absolute Maximum Ratings ( $T_c = 25^\circ C$ )**

Parameter	Symbol	Rating	Unit
Drain-Source Voltage	$V_{DS}$	100	V
Gate-Source Voltage	$V_{GS}$	$\pm 20$	V
Continuous Drain Current	$I_D @ TC=25^\circ C$	100	A
	$I_D @ TC=75^\circ C$	76	A
	$I_D @ TC=100^\circ C$	63	A
Pulsed Drain Current <sup>①</sup>	$I_{DM}$	300	A
Total Power Dissipation( $TC=25^\circ C$ )	$P_D @ TC=25^\circ C$	150	W
Operating Junction Temperature	$T_J$	-55 to 150	$^\circ C$
Storage Temperature	$T_{STG}$	-55 to 150	$^\circ C$
Single Pulse Avalanche Energy@L=0.1mH	$E_{AS}$	50	mJ
Avalanche Current@L=0.1mH	$I_{AS}$	35	A

**•Thermal resistance**

Parameter	Symbol	Min.	Typ.	Max.	Unit
Thermal resistance, junction - case	$R_{thJC}$	-	-	0.75	° C/W
Thermal resistance, junction - ambient	$R_{thJA}$	-	-	50	° C/W
Soldering temperature, wavesoldering for 10s	$T_{sold}$	-	-	265	° C

**•Electronic Characteristics**

Parameter	Symbol	Condition	Min.	Typ	Max.	Unit
Drain-Source Breakdown Voltage	$BV_{DSS}$	$V_{GS} = 0V, I_D = 250\mu A$	100			V
Gate Threshold Voltage	$V_{GS(TH)}$	$V_{GS} = V_{DS}, I_D = 250\mu A$	2.0		4.0	V
Drain-Source Leakage Current	$I_{DSS}$	$V_{DS} = 100V, V_{GS} = 0V$			1.0	$\mu A$
Gate- Source Leakage Current	$I_{GSS}$	$V_{GS} = \pm 20V, V_{DS} = 0V$			$\pm 100$	nA
Static Drain-source On Resistance	$R_{DS(ON)}$	$V_{GS} = 10V, I_D = 30A$		7	9	m $\Omega$
Forward Transconductance	$g_{FS}$	$V_{DS} = 10V, I_D = 40A$		18		s
Diode Forward Voltage	$V_{FSD}$	$I_S = 30A$			1.2	V

**•Electronic Characteristics**

Parameter	Symbol	Condition	Min.	Typ	Max.	Unit
Input capacitance	$C_{iss}$	$V_{GS} = 0V, V_{DS} = 25V$ $f = 1MHz$	-	2120	-	pF
Output capacitance	$C_{oss}$		-	940	-	
Reverse transfer capacitance	$C_{rss}$		-	48	-	

**•Switching Parameters ( $T_a = 25^\circ C$ )**

Parameter	Symbol	Condition	Min.	Typ	Max.	Unit
Total gate charge	$Q_g$	$V_{DD} = 30V$ $I_D = 10A$ $V_{GS} = 10V$	-	28	-	nC
Gate - Source charge	$Q_{gs}$		-	3.8	-	
Gate - Drain charge	$Q_{gd}$		-	5.9	-	
Turn-ON Delay time	$t_{D(on)}$	$V_{GS} = 10V,$ $V_{DS} = 50V, R$ $= 0.75\Omega, R = 6\Omega$		15		nS
Turn-ON Rise time	$t_r$			17		
Turn-Off Delay time	$t_{D(off)}$			96		
Turn-Off Fall time	$t_f$			76		

Body Diode Reverse Recovery Time	$t_{rr}$	IF=20A, dI/dt=100A/μs		47		nS
Body Diode Reverse Recovery Charge	$Q_{rr}$	IF=20A, dI/dt=100A/μs		38		nC

Note: ① Pulse Test : Pulse width ≤ 10μs, Duty cycle ≤ 1% ;

Fig.1 Gate-Charge Characteristics

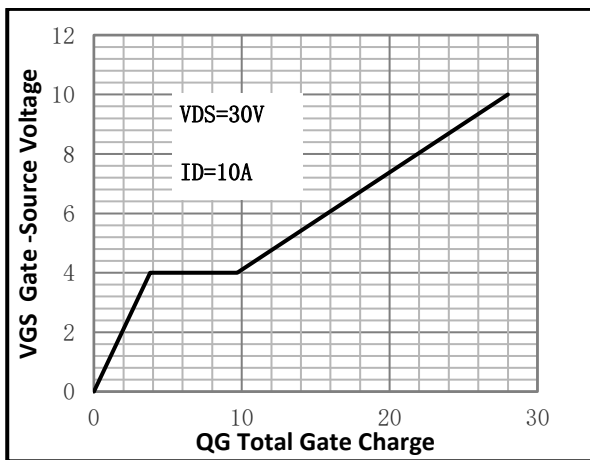

Fig.2 Capacitance Characteristics

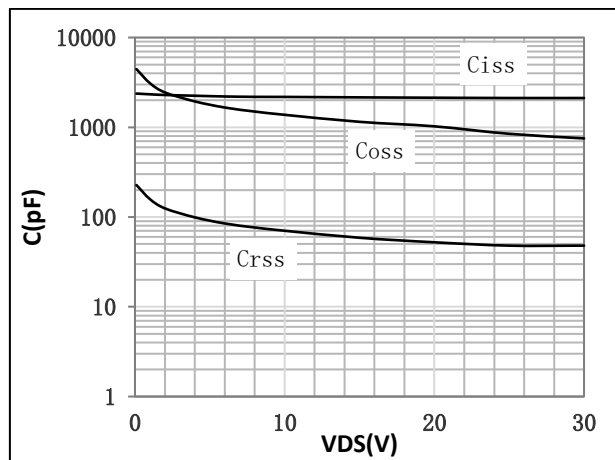

Fig.3 Power Dissipation

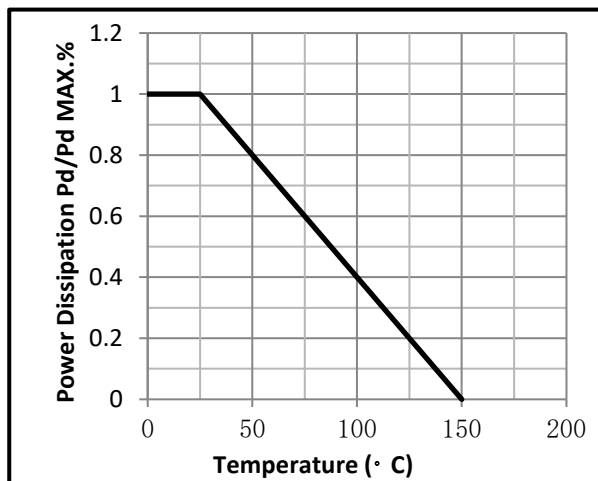

Fig.4 Typical output Characteristics

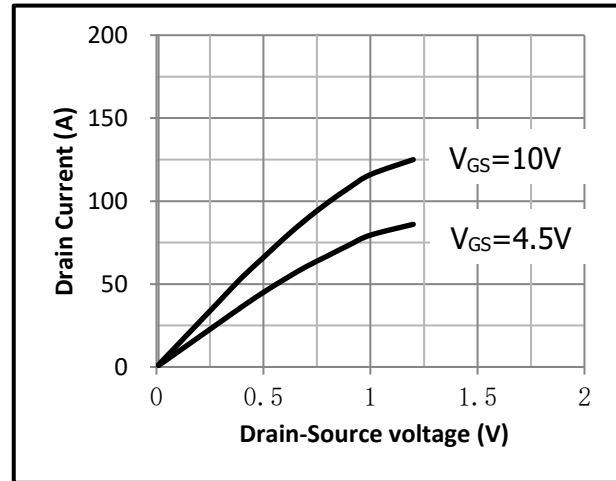

Fig.5 Threshold Voltage V.S Junction Temperature    Fig.6 Resistance V.S Drain Current

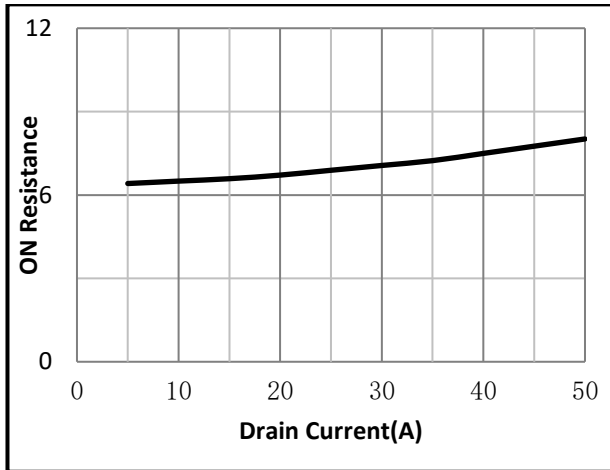
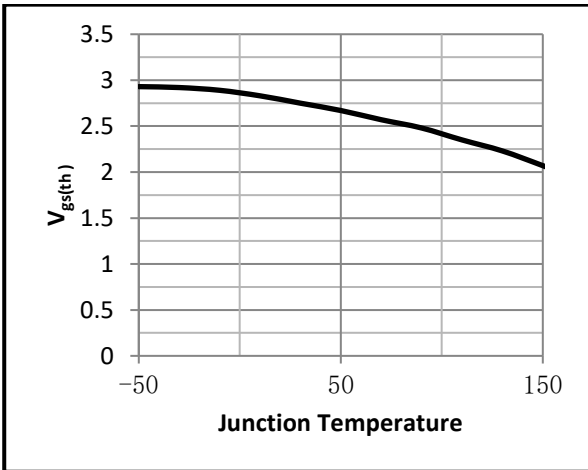

Fig.7 On-Resistance VS Gate Source Voltage

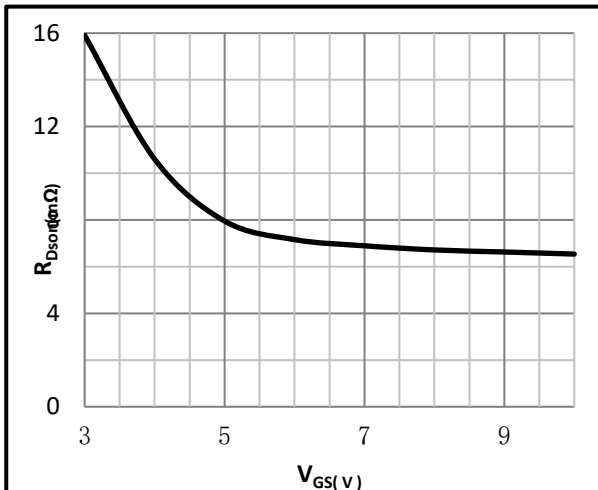

Fig.8 On-Resistance V.S Junction Temperature

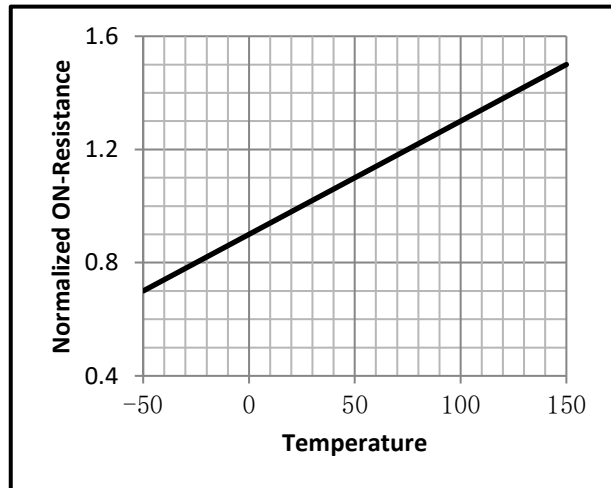

Fig.9 Gate Charge Measurement Circuit

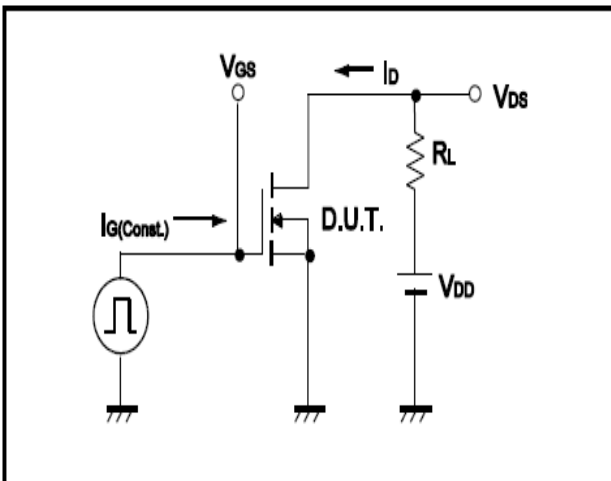

Fig.10 Gate Charge Waveform

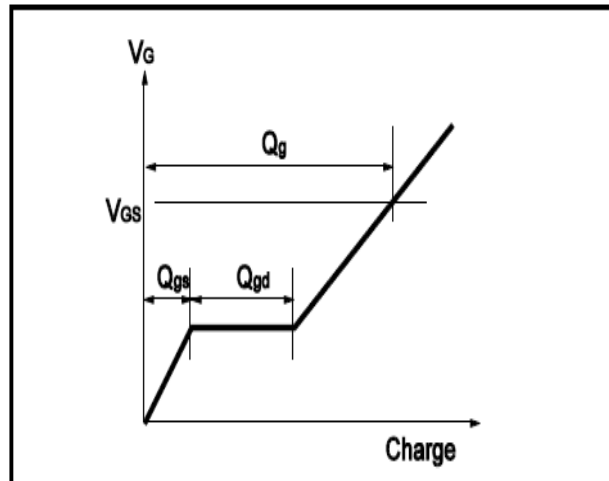

Fig.11 Switching Time Measurement Circuit

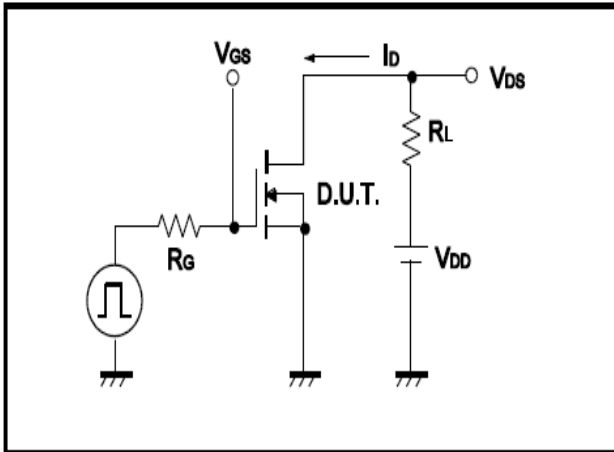
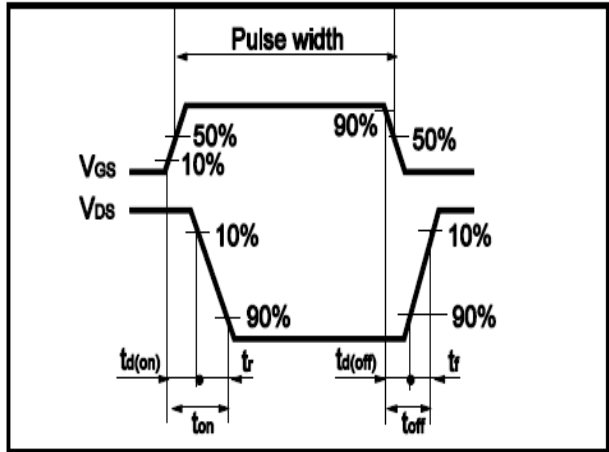

Fig.12 Switching Time Waveform



• **Dimensions (TO-220)**

Unit: mm

SYMBOL	min	nom	max	SYMBOL	min	nom	max
A	4.00		4.80	E	9.90		10.70
B	1.20		1.50	e		2.54	
B1	1.00		1.40	F	1.10		1.45
b1	0.65		1.00	L	12.50		14.50
c	0.35		0.75	L1	3.00	3.50	4.00
D	15.00		16.50	Q	2.50		3.00
D1	5.90		6.90	Q1	2.00		3.00
				ΦP	3.60		3.90

